



LET VERTIKAL DO
THE HEAVY LIFTING FOR YOU

GOODS LIFTS

Home Elevators

customized lifting goods &
material handling equipment

Models

Easy lift

Mini lift

Economy lift



Indonesia



+62821-2525-3939
+62878-8830-3939



info@vertikal-lift.com

www.vertikal-lift.com

Always deliver more than expected

PRODUCT FEATURES

Need a hand carrying cargo to the top floor of your home? Let Vertical Lifts do the heavy lifting for you. Goods Lifts is your go-to provider for home lifts across the nation. Here's what we have to offer you.

Durability

When you have a Goods Lifts installed in your home, you can rest assured it's there for the long haul. That's because they're built with durability in mind. We use rugged aluminum and stainless steel so you never have to worry about rust or corrosion. We even made sure to weather seal the rotary limit switches to guarantee endless smooth, precise stops. Once you have one of our home lifts, you'll never need another one again.

Safety

Your safety is our priority. That's why our home lift has more safety features than any other model on the market. These features include:

- Dual mast design
- Spring-loaded hinges
- Self-closing gate latch
- Dual stainless steel cables rated at 3,200 lbs. each
- An automatic lockable remote

And best of all, Goods Lifts is the only home lift system that utilizes a patent pending breakthrough in safety technology. The CageArrest brake system. This system ensures that no matter what happens — your home lift will never fall.

Versatility

Here at Vertical Lift, we understand that each home presents a unique situation. Luckily, our product adapts to every situation easily because its:

- Customizable for two and three-story homes
- Equipped with a wireless remote control programmable for either two or three floors
- Can have one or two gates
- Available in three different heights

SAFETY FEATURES

Features, Benefits

- Customizable for two and three-story homes
- User friendly
- Dual mast design
- 1,000-lb lifting capacity lets you lift more in less time
- 12.5 ft. per minute lift speed for rapid lifting
- Built with rugged aluminum and stainless steel to prevent rust and corrosion
- Weather sealed rotary limit switch for smooth controlled stops at the correct level
- Wireless remote control programmable for either two or three floors
- Lockable control box to prevent unauthorized use
- Attractive design significantly increases both the charm and value of your vacation home

Key Dimensions

Outside Dimensions

- Back of Beams to Cage Front 60"
- Back of Cage to Front of Cage 53-1/2"
- Side to Side 52"

Gate Dimensions

- 36" Gate Opening

Handrail Height

- Top to Bottom 42"

Inside Dimensions

- Back to Front 49-1/2"
- Side to Side 46"

Beam Width

- Outside to Outside 31"

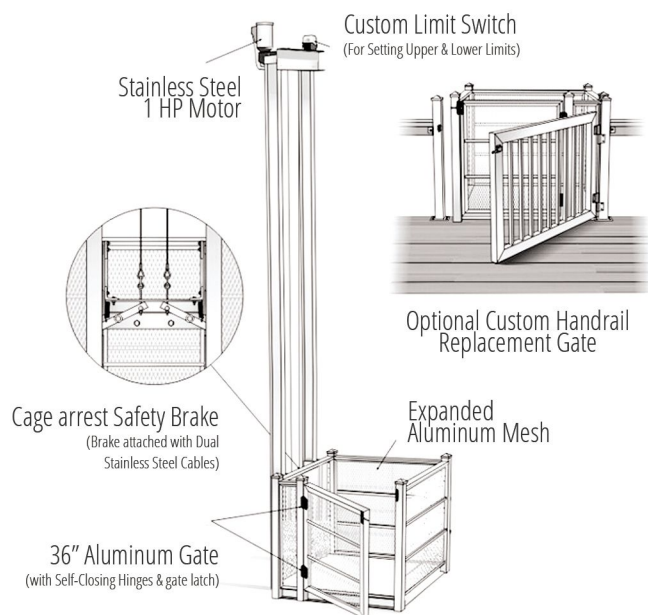

Easy Lift

Standard Equipment

- 1,000 lb. capacity
- Integrated Safety Brake
- Expanded Aluminum on all panels
- 3.5" x 5" x .33" Beam
- Model 75 Gearbox
- Twin greaseless bearing head
- 1 hp or 1.5 hp motor as supplied
- Handheld Remote Control

Engineered Stamped Plans

Interior basket dimensions:

- Side to Side: 46"
- Front to back: 49.5"

Exterior dimensions excluding L bracket:

- Side to side: 52"
- Back of beams to cage front: 60"
- Gate opening: 36"
- Mounting height: 20.5' maximum
- "L" mounting bracket

Options:

- Over-height to 32'
- Dual or triple gates
- Custom basket
- Various mounting brackets
- Matching aluminum receiving gate
- Gate Interlock
- Pan Safety Switch

Economy Lift

Standard Equipment

- 1,000 lb. capacity
- Balusters on panels 1, 2 & 3.
- Expanded aluminum on panel 4
- 3.5" x 5" x .33" Beam
- Model 75 Gearbox
- Twin greaseless bearing head
- 1 hp or 1.5 hp motor as supplied
- Handheld Remote Control

Engineered Stamped Plans

Interior basket dimensions:

- Side to Side: 46"
- Front to back: 49.5"

Exterior dimensions excluding L bracket:

- Side to side: 52"
- Back of beams to cage front: 60"
- Gate opening: 36"
- Mounting height: 20.5' maximum
- "L" mounting bracket

Options:

- Over-height to 32'
- Dual or triple gates
- Custom basket
- Various mounting brackets
- Matching aluminum receiving gate
- CageArrest™ brake kit
- Gate Interlock
- Pan Safety Switch

Mini Lift

Standard Equipment

- 500 lb. capacity
- Expanded aluminum on all panels
- 18" sides – no gate
- 3" x 4" x .24" beams
- Model 65 gearbox
- Twin greaseless bearing head
- 1/2 hp or 3/4 hp as supplied
- Handheld Remote Control

Engineered Stamped Plans

Interior basket dimensions:

- Front to back: 34.75"
- Side to side: 34.5"

Exterior dimensions excluding L bracket:

- Side to side: 38.5'
- Back of beams to cage front: 45"
- Mounting height to 19'
- "L" mounting bracket

Options:

- Single or dual gates
- Custom basket: panels 1 & 3 only
- Over-height to 30'
- Matching aluminum receiving gate-
- Various mounting brackets
- Gate Interlock
- Pan Safety Switch

FOR GOODS ONLY

**Not intended For
HUMAN TRANSPORT**





Easy Lift

Economy Lift

Mini Lift

Whatever your individual situation requires, one of our local installation teams will make sure you're happy with your very own customized home lift system. Get your very own home lift system today. Take advantage of one of the most user-friendly, attractively designed home lifts on the market.



Do you have questions?

Do not hesitate, call us or leave a message in whatsapp.

+62821-2525-3939

+62878-8830-3939

